

Dimensions Part-turn gearboxes with shaft ends on both sides

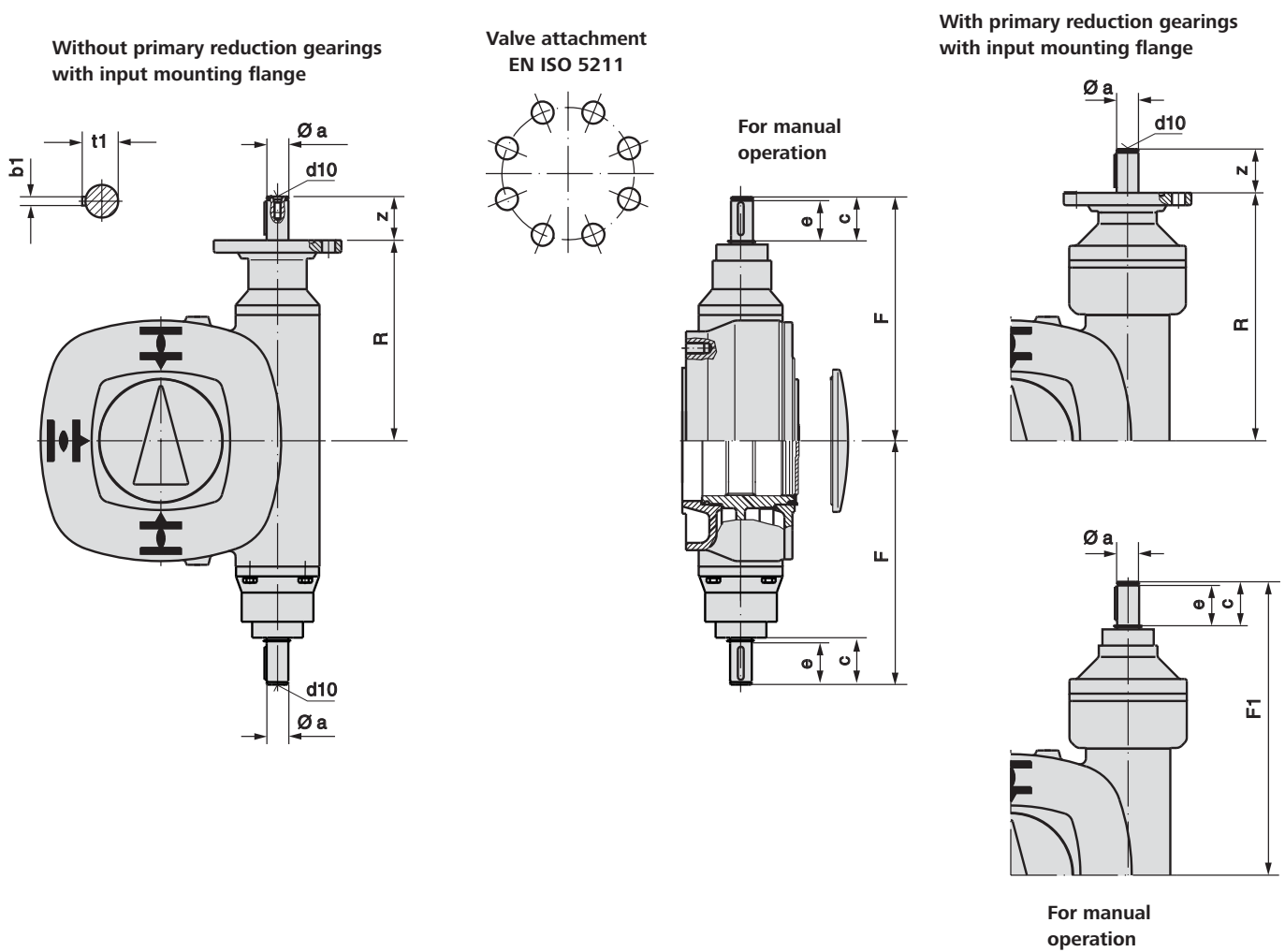

For all other dimensions, please refer to the latest issue of Dimension sheet GS 160.3 – GS 250.3

Dimensions	GS 160.3				GS 200.3					GS 250.3						
	54:1	218:1		442:1	53:1	214:1	434:1		864:1 1752:1	52:1	210:1		411:1	848:1		
F	335	-			420	-				500	-					
F1	-	380	400	380	-	485	465	485	510	-	540	560	540	585		
R	275	340			340	425			470	400	480			525		
Ø a f7	30	20	30	20	40	30	20	30	20	50	30	40	30	20	30	
b1	8	6	8	6	12	8	6	8	6	14	8	12	8	6	8	
c	60	43	60	43	73	60	43	60	43	100	60	73	60	43	60	
d10	M8	M6	M8	M6	M8	M10	M6	M10	M6	M10 M16	M10	M6	M10			
e	55	38	55	38	65	55	38	55	38	-	55	65	55	38	55	
t1	33	22.5	33	22.5	43	33	22.5	33	22.5	53.5	33	43	33	22.5	33	
z	60	40	60	40	80	60	40	60	40	100	60	80	60	40	60	

We reserve the right to alter data according to improvements made. Previous documents become invalid with the issue of this document.